

OPERATOR'S MANUAL

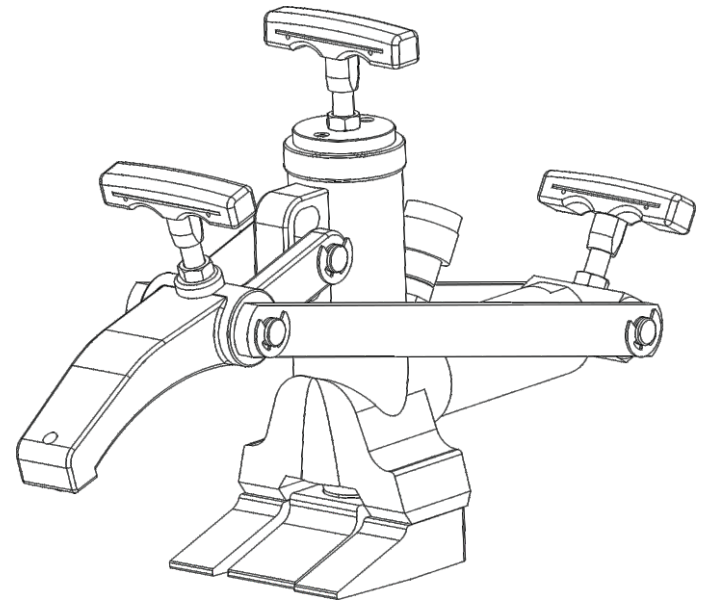

ND6225C

PORTABLE BEAD BREAKER

Operation

The optional air/hydraulic pump is capable of generating fluid pressure up to 10,000 PSI. Keep both hands on the handles and away from the clamping jaw or breaker tongue. Make certain that the tool is properly aligned on the rim before allowing the bead breaking action. Do not continue to operate the air/Hydraulic pump once the breaker rod is completely extended. Failure to comply with these instructions could result in personal injury or damage to the equipment.

1.Operation

Operation of the unit is as follows:

Make certain the tire is completely deflated.

Connect the hose of the air/hydraulic Pump to the hydraulic coupling on the Bead Breaker tool. Connect the air Supply line to the air/hydraulic pump.

Air supply should be 5-10 CFM at 100 PSI to obtain proper operating characteristics. In addition, the air line should be equipped with an air line filter.

Position the Bead Breaker so that the cup point set screw in the jaw makes solid contact with the rim and the teeth are positioned in the crevice between the bead of the tire and the rim.

Note:

When a tire has a trash guard, you may have to drive two straight tire irons between the rim and the Tire bead to get a starting point for the teeth.

Step on the PUMP end of the pump pedal. The clamping rod will begin to extend and the jaw will grip the rim.

Caution

Make Certain that the teeth are slipping in between the rim and the bead.

If not, depress the RELEASE end of the pump pedal and realign the tool.

If the tool is not positioned correctly, extending the breaker rod may damage the tool. Continue pumping until the tongue of the Bead Breaker pushes the bead free of the rim.

Depress the RELEASE end of the pump pedal.

Troubleshooting:

SYMPTOM	PROBABLE CAUSE
RODS EXTEND TOO SLOWLY	Insufficient hydraulic pressure from pump 1. Check air supply (5-10CFM@100PSI) 2. Check clearance of inlet check ball, ball must be flush with or below end of filter adapter.
RODS FAIL TO RETRACT	Hydraulic pump does not release 1. Dirt under pedal in release valve area-Clean pedal. Bearing is misaligned on breaker rod-Correct or replace. Broken or weak springs-Replace.
BOTH RODS EXTEND AT THE SAME TIME	Hydraulic pressure in breaker cylinder increases before clamping rod is fully extended. 1. Sequence ball not seated or broken or weak spring-correct or Replace. 2. Loose screw and ball not seated-correct or Replace.
BREAKER ROD RETRACTS AFTER CLAMPING ROD	Hydraulic pressure in breaker cylinder is not being released. 1. Fluid return ball did not reseat-correct or Replace. 2. Dirt plugging return port, clean. Weak or broken spring in breaker cylinder-Replace.
PUMP DOES NOT RECIPROCATE	Air piston stuck. 1. Check cylinder bore of pump for contamination or lack of lubrication. 2. Piston poppet not sealing-Replace.
PUMP RECIPROCATES RAW WILL NOT EXTEND	Check prime. 1. Depress both air valve and hydraulic release valve at the same time.
PUMP EXTENDS RAM BUT WILL NOT HOLD SYSTEM PRESSURE.	1. Outlet check ball not sealing properly-Correct or Replace. 2. Release valve mechanism not sealing properly. Check pin, ball, release poppet and poppet retainer-Correct or Replace.
PUMP EXTENDS RAM BUT WILL NOT BUILD TO MAXIMUM PRESSURE. NO VISIBLE SIGNS OF LEAKAGE	1. Check air supply (5-10CFM@100psi) 2. Check for internal leakage. A. Release valve mechanism. B. Low relief valve setting. C. Inlet check ball not seating properly-Correct or Replace.
PUMP EXTENDS RAM BUT WILL NOT BUILD MAXIMUM PRESSURE. VISIBLE SIGN OF LEAKAGE THROUGH AIR EXHAUST MUFFLER.	1. Check piston sub-assembly. A. Replace copper gasket and assemble in vertical position. B. Replace piston packing.

. 2 .

Parts List:

ITEM	DESCRIPTION	QTY	ITEM	DESCRIPTION	QTY
1	Screw M10×10	2	24	O-ring φ 36.7×3.5	2
2	Claw	1	25	Ring φ 44× φ 38×1.5	2
3	Bolt M12	3	26	Piston rod	1
4	Handle	3	27	Screw M12×55	1
5	Cylinder body	1	28	Spring A	1
6	ring-B	1	29	Screw M6×30	1
7	Stop collar	1	30	Copper washer	1
8	ring-A	1	31	φ 8 steel ball	1
9	Cylinder cover	1	32	φ 6 steel ball	2
10	Screw M6×45	3	33	ball seat	1
11	Copper washer	3	34	Spring	1
12	O-ring φ 47.5×3	1	35	Screw	1
13	Ring φ 53× φ 48.5×1.2	1	36	O-ring φ 6.8×3.1	1
14	Joint block	4	37	Ring φ 12× φ 7×1.5	1
15	Spring B	1	38	Pin φ 10×55	1
16	Piston rod	1	39	Snap ring	1
17	Coupler-A	1	40	Shaft	1
18	Screw	1	41	Adjusting shaft	1
19	O-ring φ 37.5×3	1	42	Connection rod	2
20	Ring φ 43× φ 38.5×1.2	1	43	Connector	1
21	Cylinder	1	44	Foot	2
22	Y-seal φ 45× φ 38×5	2	45	Extrusion leg	1
23	Ring φ 45× φ 38×1.5	2	46	Screw M12×40	4

. 3 .

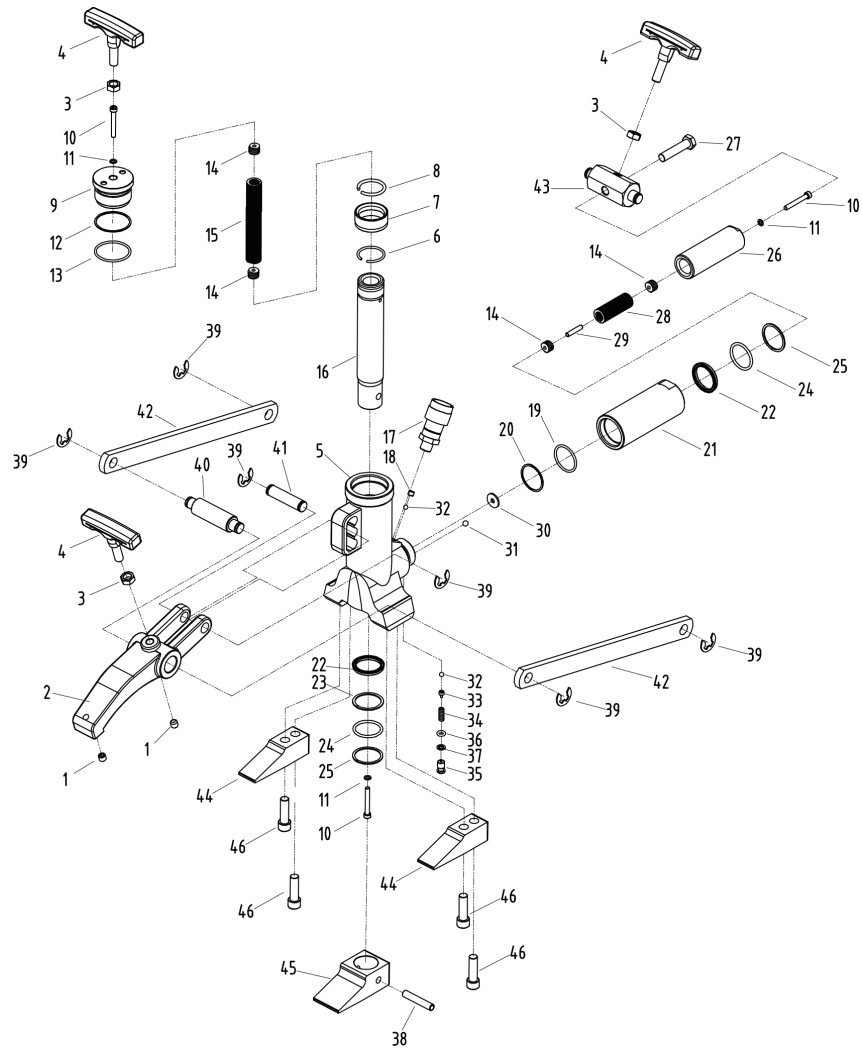

Description

The ND6225C Bead Breaker is used on all types of rims. The distance between claw and extrusion leg is adjusted to 180mm, 190mm, 200mm. Activated by air hydraulic pumps with maximum 10,000psi output pressure. It is ideal for use with truck, farm tractor, grader, combine, and skidder tires.

Safety information & Disclaimer

To avoid personal injury or property damage while using this product, read and follow all DANGERS, WARNINGS, CAUTIONS, and INSTRUCTIONS that are attached to, or included with, this product.

1. Follow the instructions of the tire manufacturer and the vehicle manufacturer when deflating, demounting, mounting, and inflating tires.
2. These operating instructions do not apply to any specific rim. Therefore, contact the rim manufacturer for the correct procedure for your rim.